

Shooting Board

Side View

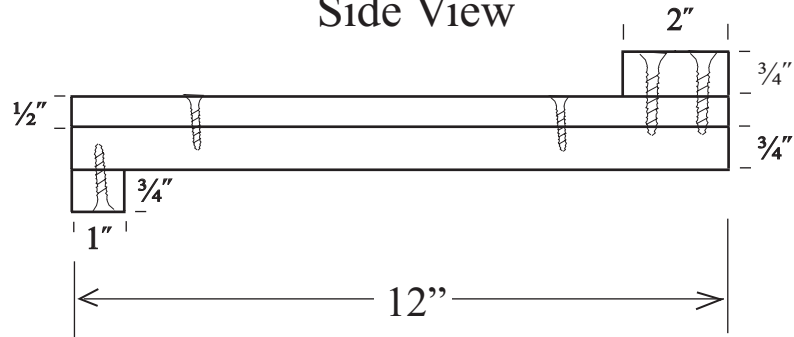

Top View

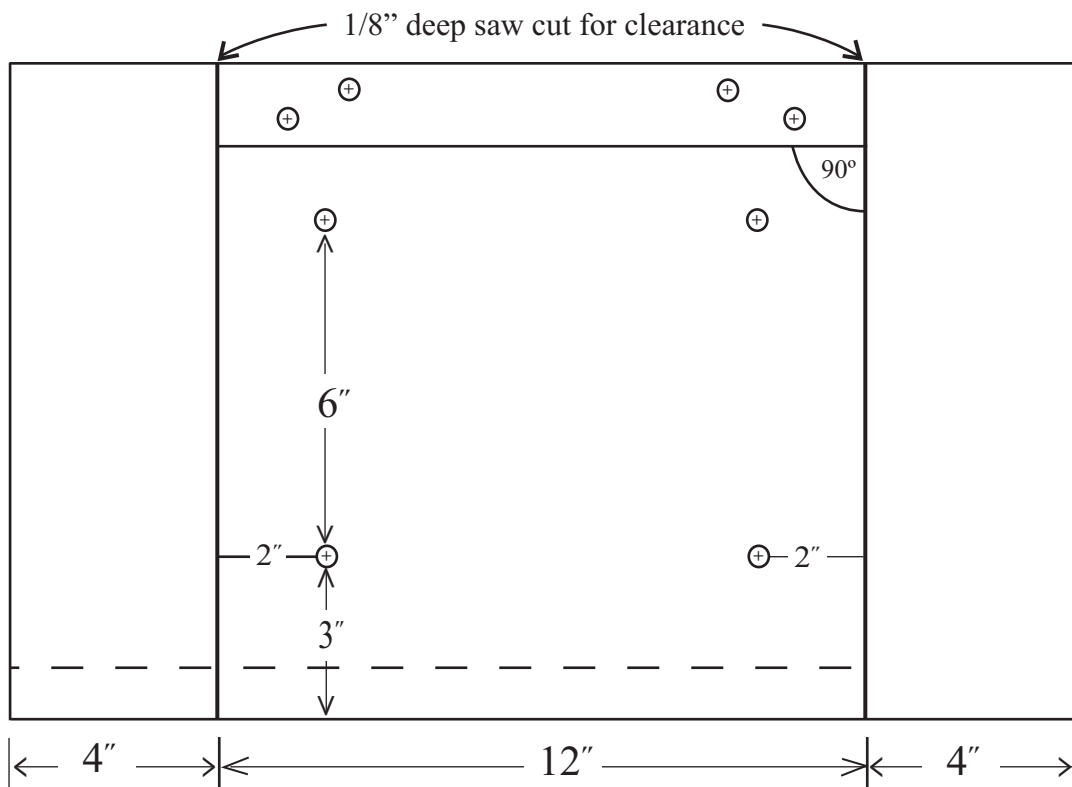

End View

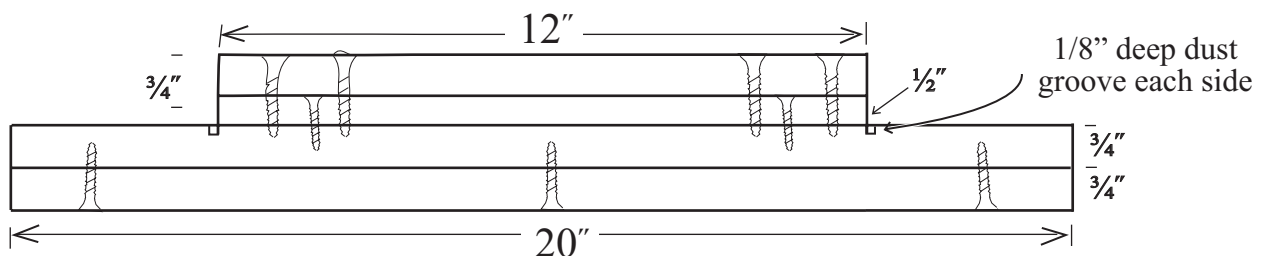

Use MDF for Board & fixtures and Hardwood for stops.
Glue & Screw parts together.

Edge Shooting Board

(for a left hand version move the 1/2" MDF to right side.)

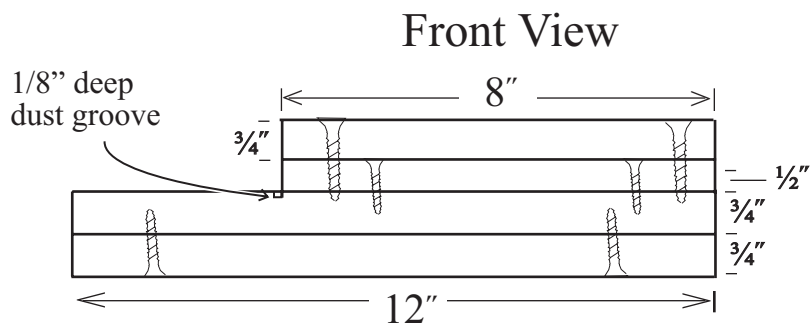
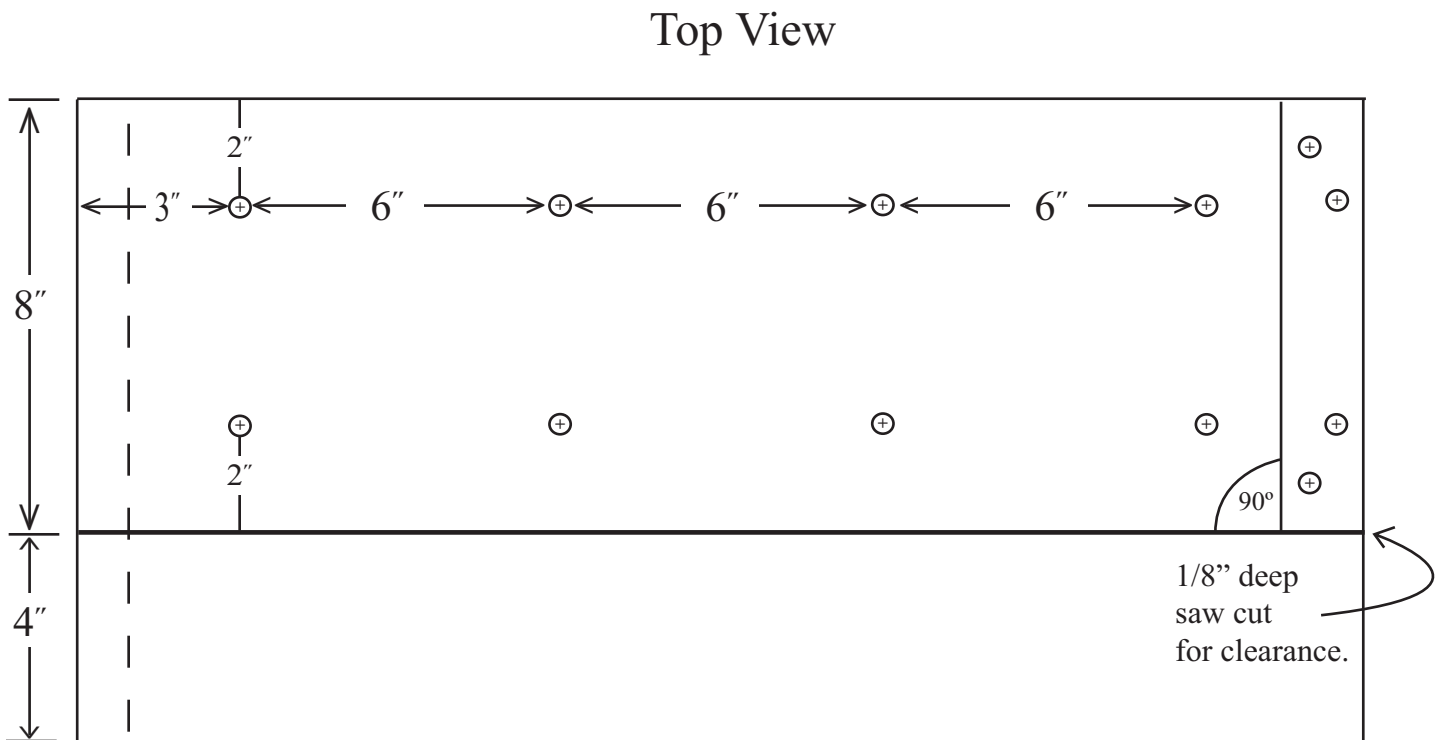
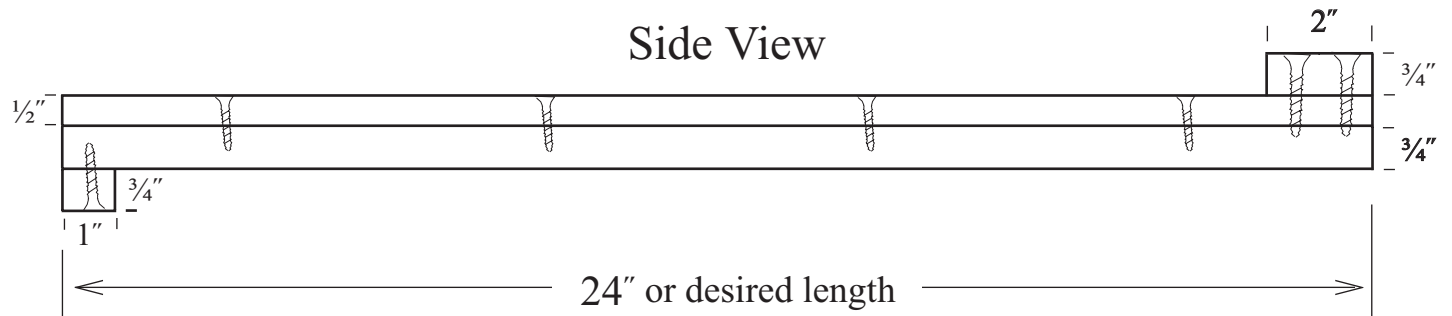

Use MDF for Board & fixtures and Hardwood for stops.

Glue & Screw parts together.

Shooting Board Fixtures

45° Miter Fixture
MDF

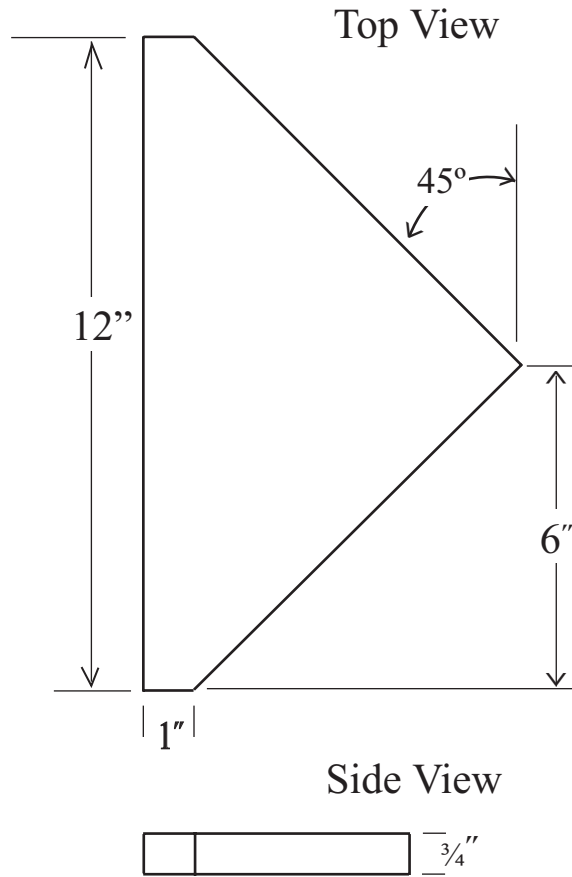

45° Miter
'Bird House'
Fixture
MDF and Hardwood

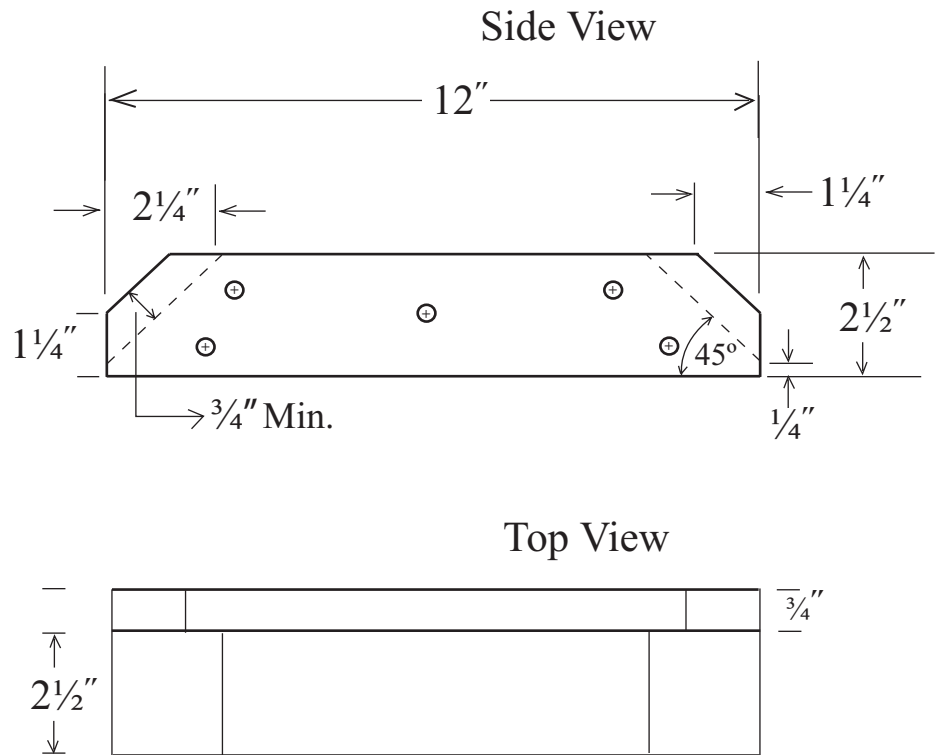

Shooting Boards & Fixtures



Shooting Board



Edge Shooting Board



45° Miter Fixture



45° Miter 'Bird House' Fixture